

**Walkie Counterbalance
Stacker Models**

Platinum WCX Series

Specification Sheet



3,000 - 4,000 lbs.

MAIN TRUCK SPECIFICATIONS

CHARACTERISTICS	1	Manufacturer's Name		UniCarriers	UniCarriers	
	2	Model	Model designation	WCX30	WCX40	
	3		Long model code	WCXT2W5G30V	WCXT2W5G40V	
	4	Rated Load Capacity	At 24" (610) load center	lb (kg)	3000 (1360)	4000 (1810)
	5	Power Type	Electric	voltage	24v	24v
	6	Operator Type			Walkie Counterbalance	Walkie Counterbalance
DIMENSIONS	7	Tire Type	Drive / load		Poly / Poly	Poly / Poly
	8	Wheels	Number - drive / load	x=driven	1x / 2	1x / 2
	9	Overall Dimensions	Length (to face of forks)	in (mm)	78.3 (1990)	78.3 (1990)
	10		Width	in (mm)	37.3 (950)	37.3 (950)
	11	Mast (3F385)	Maximum fork height (MFH)	in (mm)	152 (3850)	152 (3850)
	12		Fork lowered height (TOF)	in (mm)	1.6 (40)	1.6 (40)
	13		Mast lowered (OHL)	in (mm)	71.1 (1805)	71.1 (1805)
	14		Mast extended with LBR	in (mm)	200.7 (5100)	200.7 (5100)
	15		Standard freelif with LBR	in (mm)	23.3 (590)	23.3 (590)
	16		Width - Class II carriage	in (mm)	32.4 (825)	32.4 (825)
	17		Height - top of standard LBR	in (mm)	48 (1220)	48 (1220)
	18	Tilt Angle	Standard mast - fwd/back	degree	3 / 3	3 / 3
	19	Forks	Length x width x thickness	in (mm)	42 x 4 x 1.5 (1070 x 100 x 40)	
	20		Spread (o.d.) - Min. / Max.	in (mm)	10 (255) / 31.6 (800)	10 (255) / 31.6 (800)
	21	Grade Clearance	Ramp breakover angle	%	24	24
	22		Departure angle	%	36	36
	23	Overhang	Front / rear	in (mm)	9.6 (245) / 7.7 (195)	9.6 (245) / 7.7 (195)
	24	Turning Radius	Minimum outside (chassis)	in (mm)	69.4 (1765)	69.4 (1765)
	25	Min Right Angle Stack	48" L x 40" W pallet (add clearance)	in (mm)	127 (3225)	127 (3225)
PERFORMANCE	26	Speeds Maximum	Travel - loaded / unloaded	mph (km/h)	2.8 (4.5) / 2.9 (4.7)	2.8 (4.5) / 2.9 (4.7)
	27		Lift - loaded / unloaded	fpm (mm/sec)	30 (152) / 50 (254)	30 (152) / 50 (254)
	28		Lowering - loaded / unloaded	fpm (mm/sec)	50 (254) / 50 (254)	50 (254) / 50 (254)
	29	Drawbar Pull Maximum	Full load / empty - 3 min rating	lb (kN)	891 (3.96) / 1023 (4.55)	596 (2.65) / 1023 (4.55)
	30	Gradeability Maximum	Full load - 5 min rating	%	11.2	11.2
WEIGHT	31	Truck Weight	No load (min. battery)	lb (kg)	6185 (2805)	6185 (2805)
	32	Weight Distribution	Full load - Drive / Load wheel each (min. battery)	lb (kg)	Consult Factory	Consult Factory
	33	Drawbar Pull Maximum	No load - Drive / Load wheel each (min. battery)	lb (kg)	Consult Factory	Consult Factory
CHASSIS & WHEELS	34	Tire Size	Full load - 5 min rating	%	10 x 5 (255 x 127)	10 x 5 (255 x 127)
	35		2W270 Mast, No Load (min. battery)	lb (kg)	10.5 x 4.5 (266 x 114)	10.5 x 4.5 (266 x 114)
	36	Wheelbase	Full load - Drive / Load wheel each (min. battery)	lb (kg)	61 (1550)	61 (1550)
	37	Tread - Center of Tire	No load - Drive / Load wheel each (min. battery)	lb (kg)	34.6 (880)	34.6 (880)
	38	Power Unit Height		in (mm)	34.6 (880)	34.6 (880)
	39	Ground Clearance	Lowest point	in (mm)	2.5 (60)	2.5 (60)
	40		Under frame, center of wheelbase	in (mm)	3.7 (90)	3.7 (90)
	41	Brake	Service	type	Regen	Regen
	42		Parking	type	Auto-Applied / Electronic Release	
DRIVE LINE	43	Steering	Manual		Tiller Arm	Tiller Arm
	44	Traction Motor	AC	kW (HP)	3.9 (5.2)	3.9 (5.2)
	45	Pump Motor	DC Series - Rating @ 20% duty cycle	kW	4.77(6.4)	4.77(6.4)
	46	Hydraulic Control ¹	Parking		Lift/Lower - Electric & Manual / Tilt Lever - Manual	
BATTERY	47	Compartment Size ²	On-demand	in (mm)	35.75 x 13.5 x 32 (905 x 340 x 815)	
	48	Battery	AC	Type	E	E
	49		DC Series - Rating @ 20% duty cycle	Ah (6-hr)	840	840
	50	Weight		lb (kg)	950 / 1500 (430 / 680)	950 / 1500 (430 / 680)
	51	Lead Length	W x L x H ("X" x "Y" x "Z") - Max.	in (mm)	20 (505)	20 (505)

¹ Optional Manual Auxiliary Lever control is available.

² Battery compartment size.
with adjustable retainers: 30.9 x 13.5 x 32
with optional rollers & side gates: 31.1 x 13.5 x 31

DIMENSIONS

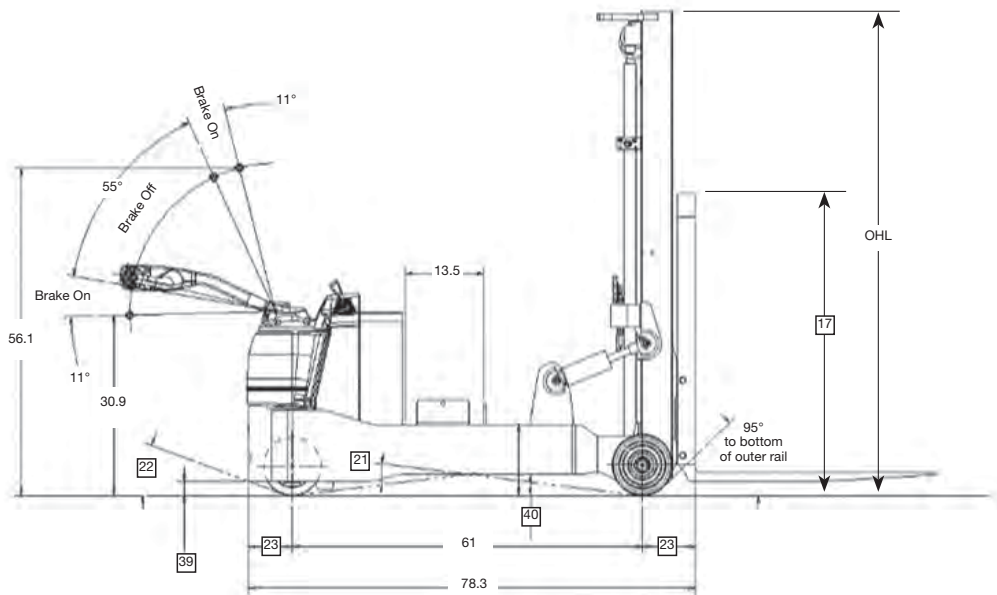
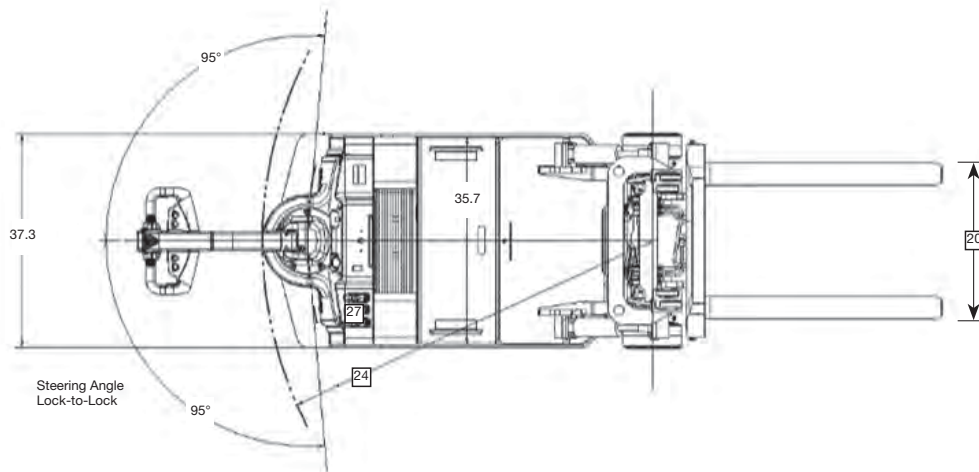

RIGHT ANGLE STACKING AISLE REQUIREMENTS

Load Width in	Load Length - in					
	30	32	36	40	42	48
30	109	111	115	119	122	128
32	109	111	115	119	121	128
36	109	111	115	119	121	127
40	109	111	115	119	121	127
42	109	111	115	119	121	127
48	108	110	115	119	121	127

Based on 4" clearance between pallets. Aisle dimensions are minimum.
Recommend 6"-10" additional clearance for ease of operation. Add another 2" for hang-on side shifter.

90° EQUAL INTERSECTING AISLE REQUIREMENTS

Load Width in	Load Length - in					
	30	32	36	40	42	48
30	66	67	68	68	69	70
32	67	67	68	69	69	71
36	67	68	69	69	70	72
40	69	69	70	71	72	73
42	70	71	71	72	73	74
48	73	74	75	76	76	78

Aisle dimensions are minimum. Recommend 6"-10" additional clearance for ease of operation.
Add another 2" for hang-on side shifter.

MAST SPECIFICATIONS & RATED CAPACITIES

Mast Name	Maximum Fork Height	Overall Height				Free Lift		Tilt Angle	Rated Capacity at 24" Load Center with 42" I.D. Outriggers	
		Lowered	Fully Extended		With LBR	Without LBR	Forward/Backward	WCX30	WCX40	
			With LBR	Without LBR				lb	lb	
	in	in	in	in	in	in	degrees			
TWO STAGE (Wide View)	2W270	106	71.1	155.8	129.8	3.9	3.9	3/3	3000	4000
	2W300	118	77.0	167.5	141.6	3.9	3.9	3/3	3000	4000
	2W330	130	82.9	179.4	153.4	3.9	3.9	3/3	3000	4000
	2W350	138	88.2	187.3	161.3	3.9	3.9	3/3	3000	4000
THREE STAGE (Full Free)	3F385	152	71.1	200.7	168.0	23.3	46.9	3/3	3000	4000
	3F430	169	77.0	218.4	185.7	29.2	52.8	3/3	3000	3950
	3F475	187	82.9	236.1	203.5	35.1	58.7	3/3	3000	3800
	3F515	203	88.2	252.0	219.4	40.4	64.0	3/3	3000	3700
	3F550	217	93.1	265.6	233.0	45.3	68.9	3/3	3000	3600

STANDARD EQUIPMENT

- 24-volt electrical system
- Brushless AC drive motor and DC pump motor
- Electronic motor controller system with AC inverter
- Multifunction digital display includes battery discharge indicator with lift lockout, (3) hour meters, and fault-code display
- Digital CAN-bus communications
- Programmable performance parameters (requires service handset tool)
- Ergonomic control handle with butterfly travel speed control
- Fingertip control of electronic lift, lower, and horn buttons
- Manual levers for lift, lower and tilt control
- Electric horn
- On/off key switch
- Large reversing switch in handle
- Adjustable battery retainers
- SB-175 red battery connector
- Poly drive tire
- Poly load wheels
- Reduced travel speed above free lift for 3F mast (or at approximately 47" for 2W mast)
- Regenerative braking
- Spring applied/electronically released brake system
- Return oil filter in hydraulic system
- Powder-coat paint finish

OPTIONAL EQUIPMENT

- Multi-function LCD display with:
 - PIN access
 - Selectable performance modes
 - BDI and speedometer
 - On-board diagnostics and troubleshooting
- Standard or polished and tapered forks in a variety of lengths
- Side shifters or auxiliary hydraulics
- Single IHR
- Battery compartment rollers with side gates
- Travel alarm
- On/off toggle switch
- Variety of battery connectors
- Mast mounted, low profile LED work lights
- Amber strobe light

Ergonomics & Operator Comfort

A wide, 190° steering arc and large, sealed, ball-bearing steering mechanism allows exceptional turning with minimal effort. Spring-loaded handle and roomy steering control head promote effortless movement into the operating range. The control handle features tubular steel construction and the control head is constructed from a fiberglass-filled polymer composite, with internal steel reinforcements, for higher strength and increased durability.

Thumb or fingertip-actuated butterfly travel speed controls provide easy and precise operation. Ergonomic, fingertip layout of the soft-touch lift, lower and horn buttons delivers comfortable operation. Large switch on the end of the control head reverses the truck's travel direction if operator contact is made.

Manual levers for lift/lower and tilt control are conveniently located on the top right of the power unit providing smooth control for feathering of the load.

Efficient Performance

Heavy-duty 5.2Hp, brushless, three-phase AC drive motor provides high power and torque to handle tough applications, with peak performance throughout the battery range. Longer run times per battery charge are achieved by using less energy per cycle.

Its advanced motor controller/AC inverter electronically distributes power as needed, to the AC drive motor, or DC pump motor, for enhanced efficiency. This system offers programmable regenerative neutral braking and proportional plugging. Its AC design eliminates forward and reverse contactors, and uses electronic travel speed control for precise, efficient performance.

A sealed, non-contact proximity switch detects when the forks are raised above free lift for 3F mast, or approximately 47" for 2W mast, triggering the controller to automatically reduce travel speed to 1.0 mph (1.5 km/h).

Optional Multi-Function Display

An optional multi-function LCD display offers PIN codes to restrict truck access, selectable performance modes for customized productivity, and a battery discharge indicator with graphic representation of remaining battery charge. Plus with on-board diagnostics, troubleshooting and adjustment.

Smart Electric Brake

Electrical braking system utilizes regenerative motor torque prior to brake actuation, for less component wear and longer life. The spring-applied/electronically released disc brake system eliminates needed adjustments, for reduced maintenance. Brake actuation occurs when the handle is in the upper and lower braking range.

Mast Design

The WCX's flat face mast design features rolled steel channels, large cross sections, and thick inner rails for increased capacity retention. Side thrust rollers on the fork carriage are easily accessed for carriage adjustment. Bolt-on mast design allows flexibility of changing mast if alternate lift heights are desired. Removable mast also allows easier serviceability of mast components.

Hydraulics

Heavy-duty DC motor, lift pump, and includes a check valve and flow regulator. Return line filtering protects the system against environmental contaminants.

Drive Unit Assembly

Quiet, spiral beveled gear drive system with sealed ball bearings, provides solid performance with low steer effort. Five-nut removal of the drive tire simplifies replacement when needed.

Frame Assembly

Rugged frame for tough dock applications. Powder coat paint for a durable, high gloss, scratch resistant finish.

Battery Compartment

The battery compartment features unique clam-type steel battery retainers to reduce side-to-side movement, keeping the battery secure.

Ease of Maintenance

Brushless AC drive motor uses fewer components and requires less maintenance for lower operating costs. Easily accessible, rotation sensing encoder is externally mounted on the drive motor for simplified replacement. Drive motor and controller feature thermal protection systems to slow or shut down truck in response to high temperatures.

Digital CAN communication between the controller and control handle reduces the number of wires in the control handle harness, for reduced maintenance. Hall Effect speed and acceleration control sensor simplifies maintenance and limits downtime due to its non-contact design with few moving parts, and with no mechanical wiping action, potentiometers, or heaters. Elimination of directional and lift contactors, with enhanced thermal capabilities means optimum performance and minimal downtime.

One-piece cover with two-bolt removal makes access to the drive unit, and major components quick and easy. All lubrication fittings are easily accessible with the truck upright and the battery in place.



SS-NIS-WCX-07-2014

Printed in U.S.A.

UniCarriers® is a registered trademark of UniCarriers Corporation.
UniCarriers Americas Corporation reserves the right to make product changes relating to colors, equipment, specifications or available options without notice.
For more information, contact your authorized Nissan Forklift by UniCarriers dealer representative.

