

UNI CARRIERS[®]

□ FORKLIFT □

SPX Series



Center Control Walkie/Rider Pallet Trucks

24 Volt AC-Powered
6,000 & 8,000 lbs. Capacities

S P E C I F I C A T I O N S

MAIN TRUCK SPECIFICATIONS

CHARACTERISTICS	1			UniCarriers	UniCarriers
	2			SPX60B	SPX80B
	3			SPXT2W3G60BV	SPXT2W3G80BV
	Manufacturer's Name				
	Model	Model designation			
		Long model code			
	Rated Load Capacity	At 24" (610) load center	lb (kg)	6000 (2720)	8000 (3630)
	Power Type	Electric		24v	24v
	Operator Type	Stand-up, Center Control		Walkie / Rider	Walkie / Rider
	Tire Type	Drive tire		Solid Rubber	Solid Rubber
		Caster Wheels		Poly	Poly
		Load Wheels		Dyalon® A Poly	Dyalon® A Poly
	Wheels	Drive/caster/load	(x=driven)	1x / 2 / 2	1x / 2 / 2
FORKS	Fork Size	Outside spread	in (mm)	27 (685)	27 (685)
	Fork Height	Raised position	in (mm)	9.25 (235)	9.25 (235)
		Lowered position	in (mm)	3.25 (82.5)	3.25 (82.5)
	Individual Fork Width		in (mm)	9.25 (235)	9.25 (235)
DIMENSIONS	Head Length	Forks raised	in (mm)	56.9 (1445)	56.9 (1445)
	Width	Chassis	in (mm)	35.1 (890)	35.1 (890)
	Tires / Wheels	Drive tire - diameter x width	in (mm)	10 x 5 (255 x 125)	10 x 5 (255 x 125)
		Caster wheels - diameter x width	in (mm)	6 x 3 (150 x 75)	6 x 3 (150 x 75)
		Load wheels - diameter x width	in (mm)	3.25 x 6 (85 x 150)	3.25 x 6 (85 x 150)
SPEED	Speed - Travel	No load	mph (kph)	9.0 (14.5)	9.0 (14.5)
		Full load	mph (kph)	7.2 (11.6)	6.2 (10.0)
	Speed - Lift / Lower	No load	sec.	3.0 / 4.7	3.0 / 4.7
		Full load	sec.	4.2 / 4.4	4.6 / 4.3
BATTERY	Compartment Size*	Length x Width x Height	in (mm)	33.2 x 13.5 x 31.6 (840 x 340 x 800)	
	Amp Hr Capacity	Max (6-hr)	Ah	840	840
	Weight	Min / Max	lb (kg)	855 / 1550 (390 / 700)	855 / 1550 (390 / 700)
	Lead Length	Position "B"	in (mm)	20 (508)	20 (508)
	Connector		type	SB-175 Red	SB-175 Red
	Battery Roller (Option)	Height from floor (forks lowered)	in (mm)	7.05 (180)	7.05 (180)

*Battery compartment size with optional rollers and side gates: 30.9 x 13.5 x 31.6 (785 x 340 x 800)

AISLE SPECIFICATIONS

SPECIFICATIONS				Single Pallet	Double Pallet	
	Fork Length	Nominal	in (mm)	48 (1220)	84 (2135)	96 (2440)
		Actual	in (mm)	47.7 (1210)	83.7 (2125)	95.7 (2430)
	Overall Truck Length		in (mm)	104.9 (2665)	140.9 (3580)	152.9 (3885)
	Face of Forks to Center	Forks raised	in (mm)	36.4 (925)	56.5 (1435)	56.5 (1435)
	of Load Wheel	Forks lowered	in (mm)	40.0 (1015)	60.1 (1525)	60.1 (1525)
	Center of Load Wheel	Forks raised	in (mm)	11.3 (290)	27.2 (690)	39.2 (995)
	to Tip of Forks	Forks lowered	in (mm)	7.7 (195)	23.6 (605)	35.6 (905)
	Wheelbase	Forks raised	in (mm)	85.3 (2165)	106.2 (2700)	106.2 (2700)
		Forks lowered	in (mm)	88.9 (2260)	109.3 (2795)	109.3 (2795)
	Grade Clearance	Between caster & load wheels	%	57	40	40
		From load wheel to fork tip	%	70	30	20
	Turning Radius	Std / With handle at 90°	in (mm)	93.5 / 98.7 (2375 / 2510)	114.5 / 119.7 (2910 / 3040)	114.5 / 119.7 (2910 / 3040)
	Right Angle Stacking Aisle*	40", 42", 48" Load Width	in (mm)	108 (2745)	146 (3710)	158 (4015)
	90° Equal Intersecting Area*	40" Load Width	in (mm)	78 (1980)	89 (2260)	91 (2315)
		42" Load Width	in (mm)	79 (2010)	91 (2315)	92 (2340)
		48" Load Width	in (mm)	82 (2085)	94 (2390)	95 (2415)
	Truck Weight	No load, without battery	lb (kg)	1750 (795)	1895 (860)	1930 (880)

*Add 6-8" for ease of operation. Includes 1" clearance on each side of load.

Note:

Single Pallet Handling: Size the forks to the exact pallet length. The load wheels will drop in the second opening of the pallet.

Double Pallet Handling: Size the forks to the exact pallet combination length. The load wheels should be specified to drop in the first opening of the second pallet to reduce the turning radius of the truck.

DIMENSIONS

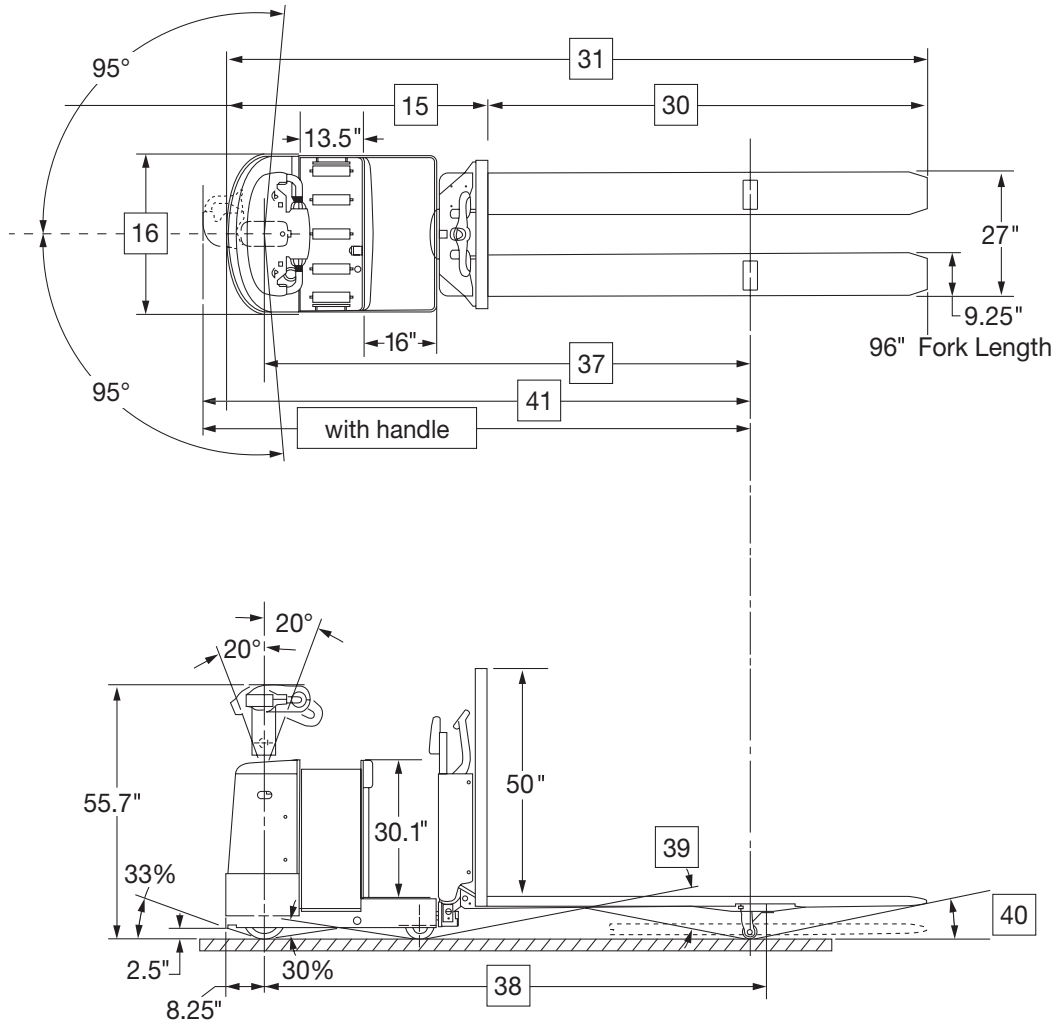

INTERSECTING AISLE REQUIREMENTS

A Working Aisle in (mm)	B Rack Width ¹ in (mm)	C Intersecting Aisle ² in (mm)
96 (2440)	102 (2590)	119 (3015)
102 (2590)	102 (2590)	111 (2810)
108 (2745)	102 (2590)	105 (2650)

¹Rack width calculated using 48" pallets and additional 6" needed for bracing.

²Minimum required aisle size to make a turn from one adjacent aisle to the next.

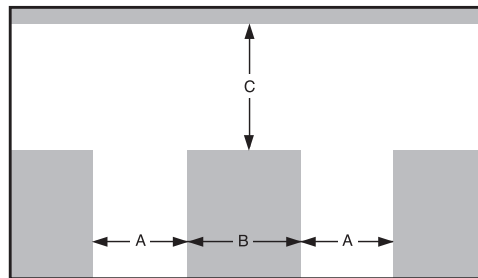

STANDARD EQUIPMENT

- 24-volt electrical system
- Brushless AC drive motor and DC pump motor
- Electronic motor controller system with AC inverter
- Digital CAN-bus communications
- Cold storage conditioning (to -20°F / -28°C)
- Programmable performance parameters (requires service handset)
- Adjustable tilt steer head with rotary travel speed and directional control
- Fingertip control of electronic lift, lower, and horn buttons
- Electric coast control
- Sidetracker
- Operator compartment padding
- Large operator platform with cushioned mat
- Electric horn
- Multi-function digital indicator
 - Battery discharge indicator with lift interrupt
 - Hour meter gauge: traction, lift, combined traction & lift
 - Fault codes
- On/off key switch
- Adjustable battery retainers
- SB-175 red battery connector
- Rubber drive tire (10" x 5") with string guard
- Heavy-duty, poly caster wheels (6" x 3") with string guards
- Dyalon® "A" load wheels: 3¼" x 6" with string guards
- Regenerative braking
- Spring applied/electronically released brake system
- Sealed switches and controller for wet, cooler and freezer applications
- Return oil filter in hydraulic system
- Motor and controller thermal protection
- Powder-coat paint finish

OPTIONAL EQUIPMENT

- Multi-function LCD display with:
 - PIN access
 - Selectable performance modes
 - BDI and speedometer
 - On-board diagnostics and troubleshooting
- Magnetic mount convenience tray with stretch wrap holder
- Electric coast control
- Fork auto-lift function to 2½" height upon release of lower button
- On/off toggle switch*
- Fixed steer head*
- Operator compartment knee pad
- Battery compartment rollers with side gates
- Battery gate interlock switches
- Travel alarm
- Stainless steel axles and linkage pivot pins
- Vulkollan® load wheels
- Non-marking rubber, traction treaded rubber or flat poly drive tire options

* Available at no charge.

ERGONOMICS & COMFORT

T-style, adjustable steer head combined with a cushioned platform and fully padded compartment provide an impressive workplace to achieve maximum operator comfort and reduced fatigue resulting in sustained productivity. The steer head's wide, 190° steering arc allows for precise maneuvering in tight spaces with minimal effort.

Ergonomic layout of the truck's control head includes rotary-thumb travel speed controls, which can be operated from either side. Ergonomic placement of lift, lower and horn buttons provides intuitive fingertip control. Soft-touch switches also simplify load lifting and lowering.

Standard coast control allows operator to let the truck coast for more efficient order picking.

Rubber padded, intermediate handrail features thick tubular construction for greater dependability. Large, sealed buttons provide operator with greater control of fork raise/lower and reverse travel commands, as well as horn functions. It's bolted to the truck frame for faster replacement or repair.

The SPX is designed with a large operator platform. Combined with a compact hood design, operators have several comfortable positions, to reduce fatigue and promote sustained productivity. Soft, cushioned platform mat provides added comfort.

EFFICIENCY & CONTROL

Advanced motor controller/AC inverter electronically distributes power as needed to the AC drive motor or DC pump motor. System offers programmable regenerative neutral braking and proportional plugging. Its AC design eliminates forward and reverse contactors, with electronic travel speed control for precise, efficient performance.

An optional multi-function LCD includes three hour meters and Personal Identification Number (PIN) codes to restrict truck access for greater fleet control. It provides access to customized performance settings and displays a battery discharge indicator with graphic representation of the remaining battery charge. The optional feature also offers on-board diagnostics and troubleshooting without the need for a separate hand tool.

EFFICIENT PERFORMANCE & GREATER UPTIME

Heavy-duty 5.2 Hp, brushless, three phase AC drive motor, provides high power and torque to handle tough applications. Motor delivers peak performance throughout the battery range. Longer run times per battery charge are achieved by using less energy per cycle.

SPX includes an IP65 rated sealed controller. Sealed switches and logic boards allow operation in multiple environments including coolers, wet rooms and freezers down to -20°F (-28.9°C).

Digital CAN communication between the controller and control handle uses just four wires in the control handle harness to send multiple signals. Hall Effect speed and acceleration control sensor simplifies maintenance and limits downtime due to its non-contact design with fewer moving parts, and no mechanical wiping action, potentiometers, or heaters. Elimination of directional and lift contactors combined with enhanced thermal capabilities mean optimum performance and minimal downtime.

Electrical braking system uses regenerative motor torque prior to disc brake actuation, for less component wear and longer life. The spring-applied/electronically released disc brake system eliminates the need for adjustments. Brake actuation occurs when the handle is in the upper and lower braking range.

RUGGED FORK ASSEMBLY

Forks are 9¼" wide, constructed from ¼" plate steel, and designed with a reinforced tip for extra durability. Tapered ¼" steel fork slides facilitate pallet entry and exit without the use of entry rollers or discs. Various lengths available for both double and single pallet fork options. All come with a standard 27" wide fork spread.

Steel push rods are constructed from 1½" x 1½" solid bar stock to absorb high impact shocks caused by dock boards and dock plates and never need replacing. Push-type design achieves full 6" of lift without tie rods extending beyond the fork plane, preventing the possibility of damage and reducing maintenance costs.

Tie rods are positively aligned and pinned, so no field adjustments are required. Full-length, angle iron reinforcements enhance strength to reduce torsion, for increased durability and longer life. Each fork extends under the battery box for greater strength.

DURABLE DESIGNS

Exclusive articulated frame design with 5-point suspension incorporates drive wheel and swivel caster wheels that are separate from the rear load bearing frame, permitting smooth, independent movement of rear frame and chassis, resulting in easier negotiating over dock plates and uneven floors.

The SPX Series is manufactured with a rugged frame for tough applications. Powder coat paint, inside and out, delivers a durable, high gloss, scratch resistant finish. Heavy-duty integrated lift system (DC motor, lift pump and fluid reservoir) includes a check valve and flow regulator. Lift limit switch is not needed since the controller cuts the pump. Return line filtering protects the system against environmental contaminants. A quiet, spiral beveled gear drive system with sealed ball bearings provides solid performance with low steer effort.

LOWER OPERATING COSTS

Brushless AC drive motor uses fewer components and requires less maintenance for lower operating costs. Easily accessible, rotation sensing encoder is externally mounted on the drive motor for simplified replacement. Motor and controller feature thermal protection system to slow or shut down truck in response to high temperatures.

Unique steer race and enclosed frame design help keep major components (such as drive motor, controller and hydraulic system) free from debris kicked up by the drive tire for less maintenance and longer life.

One-piece cover with two-bolt removal makes access to the drive unit, and major components quick and easy. Five nut removal of the drive tire simplifies replacement when needed. All lubrication fittings are easily accessible with the truck upright and the battery in place.

Optional auto-lift feature ensures forks are automatically at maximum lift height during operation, providing ample clearance to reduce pallet and or load carry component damage.

Electrical braking system uses regenerative motor torque prior to disc brake actuation, for less component wear and longer life. The spring-applied/electronically released disc brake system eliminates the need for adjustments.



UniCarriersAmericas.com

SS-SPX 09-2015 Printed in U.S.A.

UniCarriers® is a registered trademark of UniCarriers Corporation. UniCarriers Americas Corporation reserves the right to make product changes relating to colors, equipment, specifications or available options without notice. For more information, contact your UniCarriers representative.

